

NOTE ORIENTATION OF SOCKETS

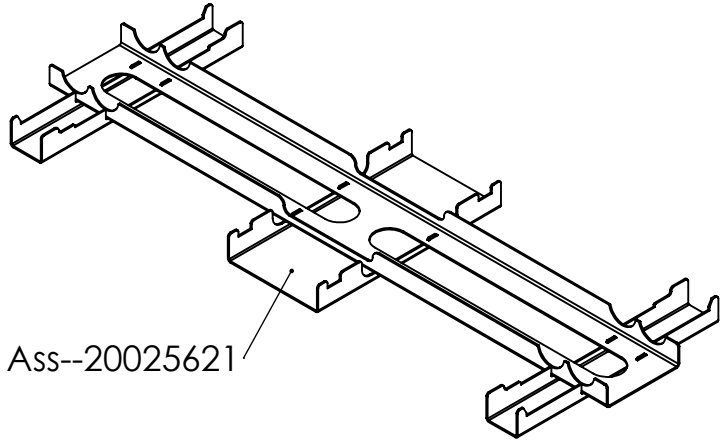

Weld using jig Ass--20025621

BOM Table			
NO	Part Number	Description	QTY
1	Par--20003291	M10 Hex Rivnut	4
2	Ass--20001676	Pozimount End Arm PZX1	2
3	ASS--20053185	FCS1 back plate and sockets	1

Description		FCS1 Gantry 1000Mm Centres - PZX1A	
UNLESS OTHERWISE SPECIFIED: DIMENSIONS ARE IN MILLIMETERS	Created Date: 31 March 2022	DRW - REV REV - A-005	See Below - Special Notes
	Created Date: 31 March 2022		
SURFACE FINISH: Powder Coated	Bend Tool:		
Created By System Administrator Unicol Engineering Green Road Oxford OX3 8EU	Material:	Part Number & Part Revision ASS--20028623 REV - A-005	SCALE:1:12 DO NOT SCALE DRAWING SHEET 1 OF 1
	Gauge:		
WEIGHT: 10.35		Kg	