

BOM Table			
NO	Part Number	Description	QTY.
1	ASS--20052951	FCS4 back plate and sockets	1
2	Ass--20025139	Pzx9 - Pozimount End Arm Type 9	2

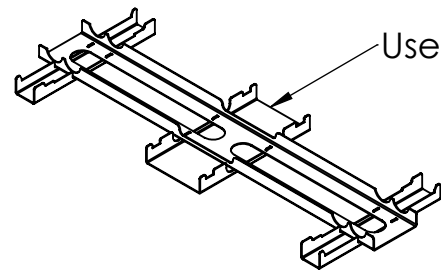

Description		FCS4 Pzx9 Twin Socket Gantry 1100mm Centres	
UNLESS OTHERWISE SPECIFIED: DIMENSIONS ARE IN MILLIMETERS	Saved Date: 31 March 2022	DRW - REV REV - A-013	See Below - Special Notes
	Created Date: 31 August 2021		
SURFACE FINISH: Powder Coated	Bend Tool:		
Created By System Administrator	Material:		
Unicol Engineering Green Road Oxford OX3 8EU	Gauge:		
		Part Number & Part Revision Ass--20025642 REV - A-013	

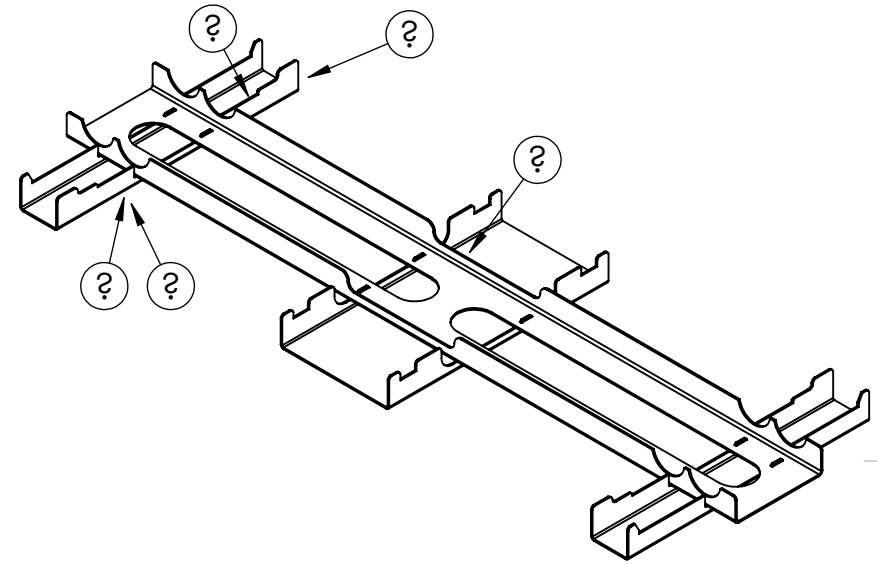
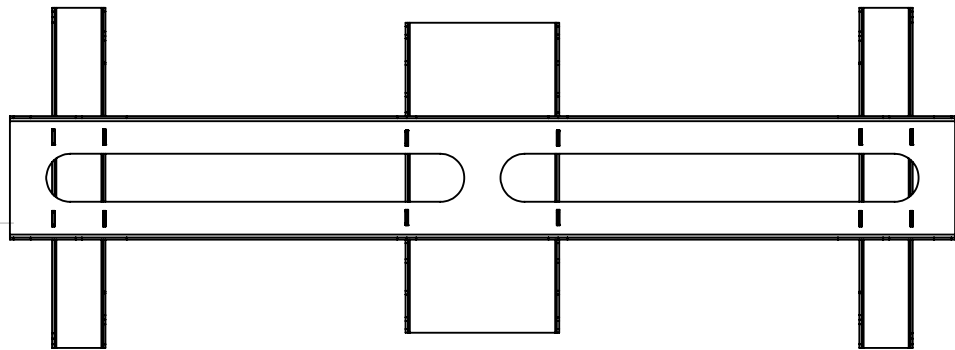
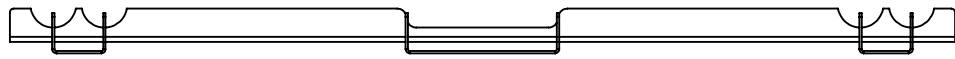

BOM Table			
NO	Part Number	Description	QTY.
1	PAR--20043092	PZX Gantry Jig Centre plate	1
2	PAR--20043087	Gantry Screen Rail Socket Jig Plate	2
3	Par--20038709	Gantry Screen Rail Socket Jig	1

Description		Gantry Screen Rail Socket Jig	
UNLESS OTHERWISE SPECIFIED: DIMENSIONS ARE IN MILLIMETERS	Created Date: 26 August 2021	DRW - REV REV - A-013	See Below - Special Notes
	Created Date: 31 August 2021		
SURFACE FINISH: Powder Coated	Bend Tool:		
Created By System Administrator Unicol Engineering Green Road Oxford OX3 8EU	Material:	Part Number & Part Revision Ass--20025621 REV - A-013	
	Gauge:		
	WEIGHT: 10.15	Kg	